

transport spécial national et international  
levage - manutention - entreposage



route du Molliau  
CH - 1131 TOLOCHENAZ

tél. +41 (0)21 804 94 94  
fax +41 (0)21 804 94 10

[www.friderici.com](http://www.friderici.com)

## CAMION 68

### RENAULT C520 10x4

### EFFER 685 6S + Jib 6S

Camion avec grue 18.8 t / 57.86 tm

LKW mit 18.8 t kran / 57.86 tm

1



<b>Poids à vide*</b>	<b>25.25 tonnes</b>	<b>Charge utile</b>	<b>14.75 tonnes</b>
<b>Dimensions du pont</b>	<b>6.5 x 2.48 mètres</b>	<b>Hauteur du pont</b>	<b>1.21 mètres</b>
<b>Hauteur position route</b>	<b>4 mètres</b>	<b>Portée max.</b>	<b>30.09 mètres</b>

\*Poids à vide avec Jib: 26.25 to

# DIMENSIONS - ABMESSUNGEN

2

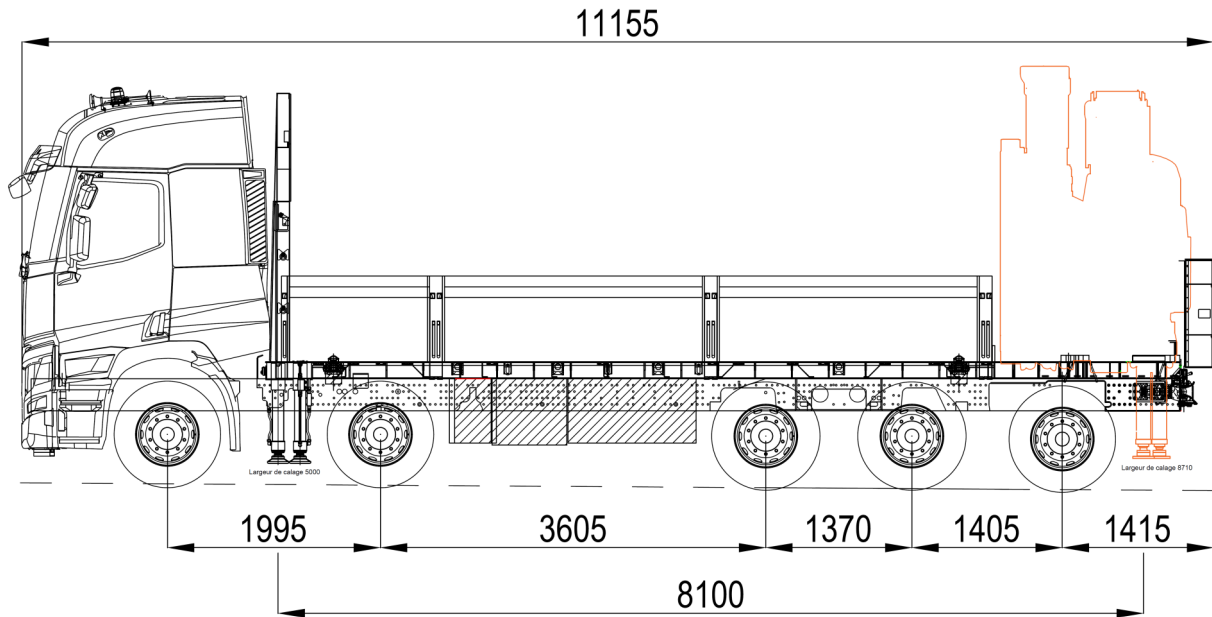

EFFER 685 6S

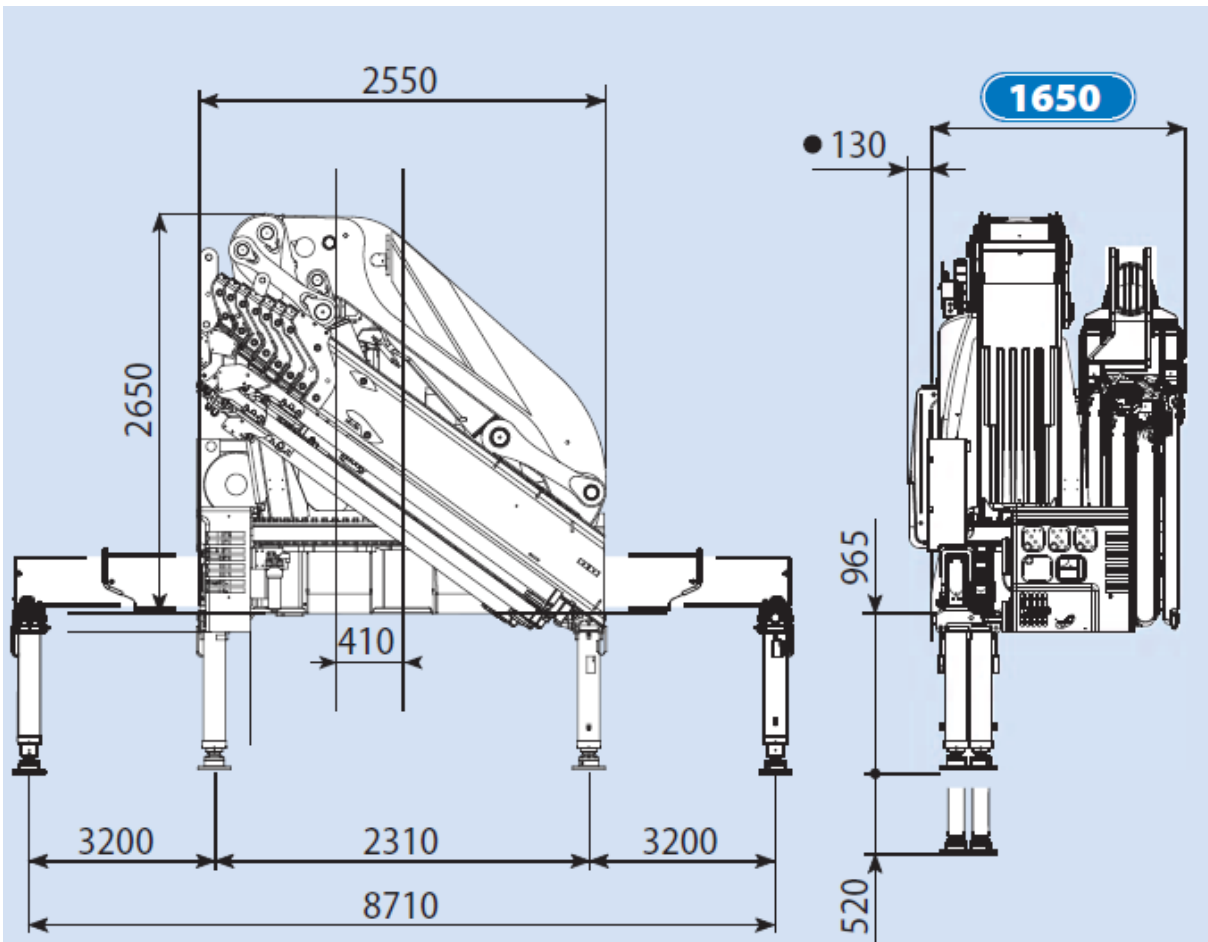

Base de calage : 8.1 x 8.71 - 5m  
 Abstützbasis : 8.1 x 8.71 - 5m

# CAPACITE DE LEVAGE - TRAGLASTEN

## DIAGRAMME DE LEVAGE ARBEITSBEREICHE

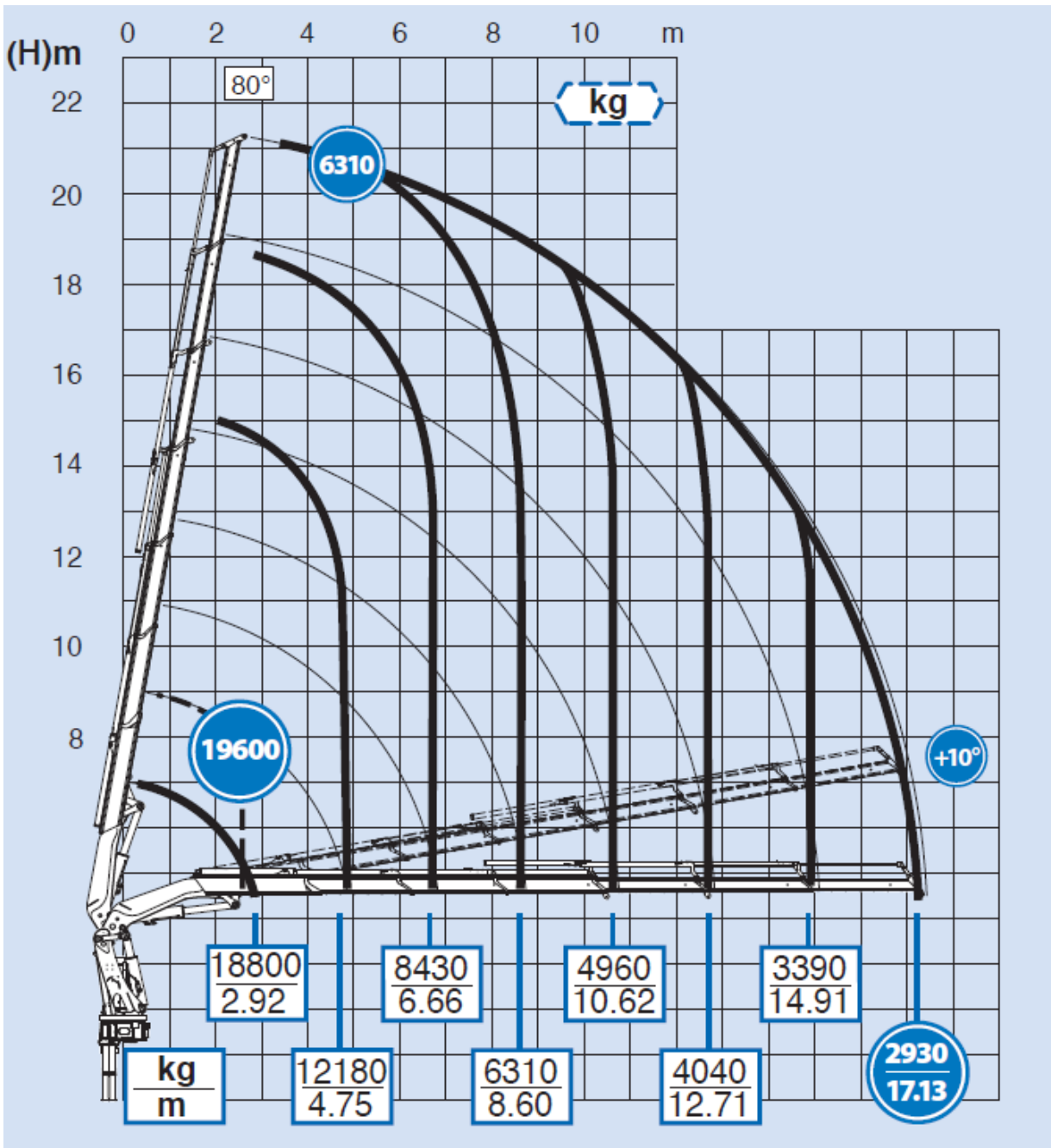

# CAPACITE DE LEVAGE - TRAGLASTEN

## DIAGRAMME DE LEVAGE AVEC JIB ARBEITSBEREICHE MIT DEM JIB

4

EFFER 685 6S

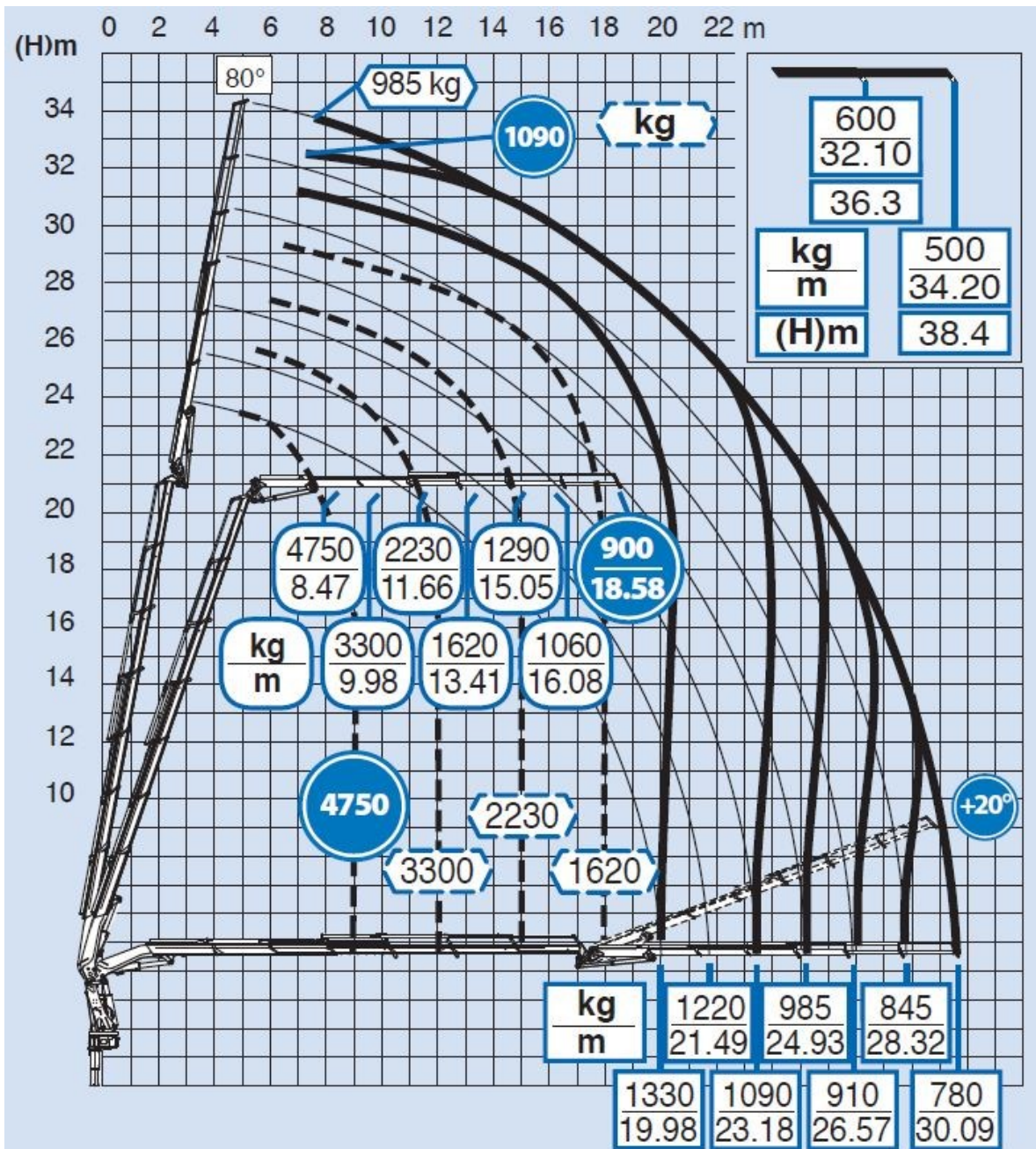

# CAPACITE DE LEVAGE - TRAGLASTEN

DIAGRAMME DE LEVAGE AU TREUIL  
ARBEITSBEREICHE MIT SEILWINDE

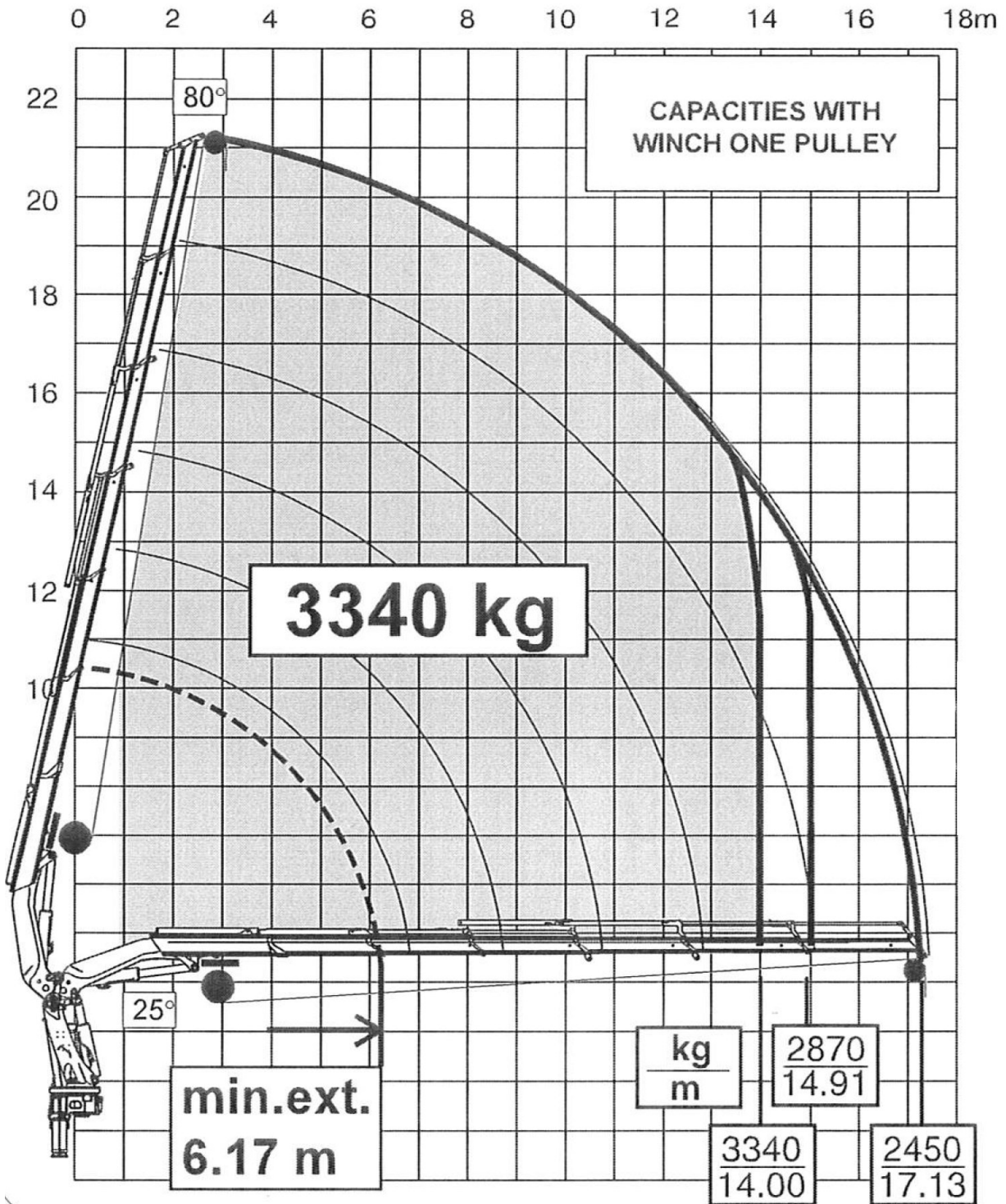

# CAPACITE DE LEVAGE - TRAGLASTEN

DIAGRAMME DE LEVAGE AU TREUIL  
ARBEITSBEREICHE MIT SEILWINDE

6

EFFER 685 6S

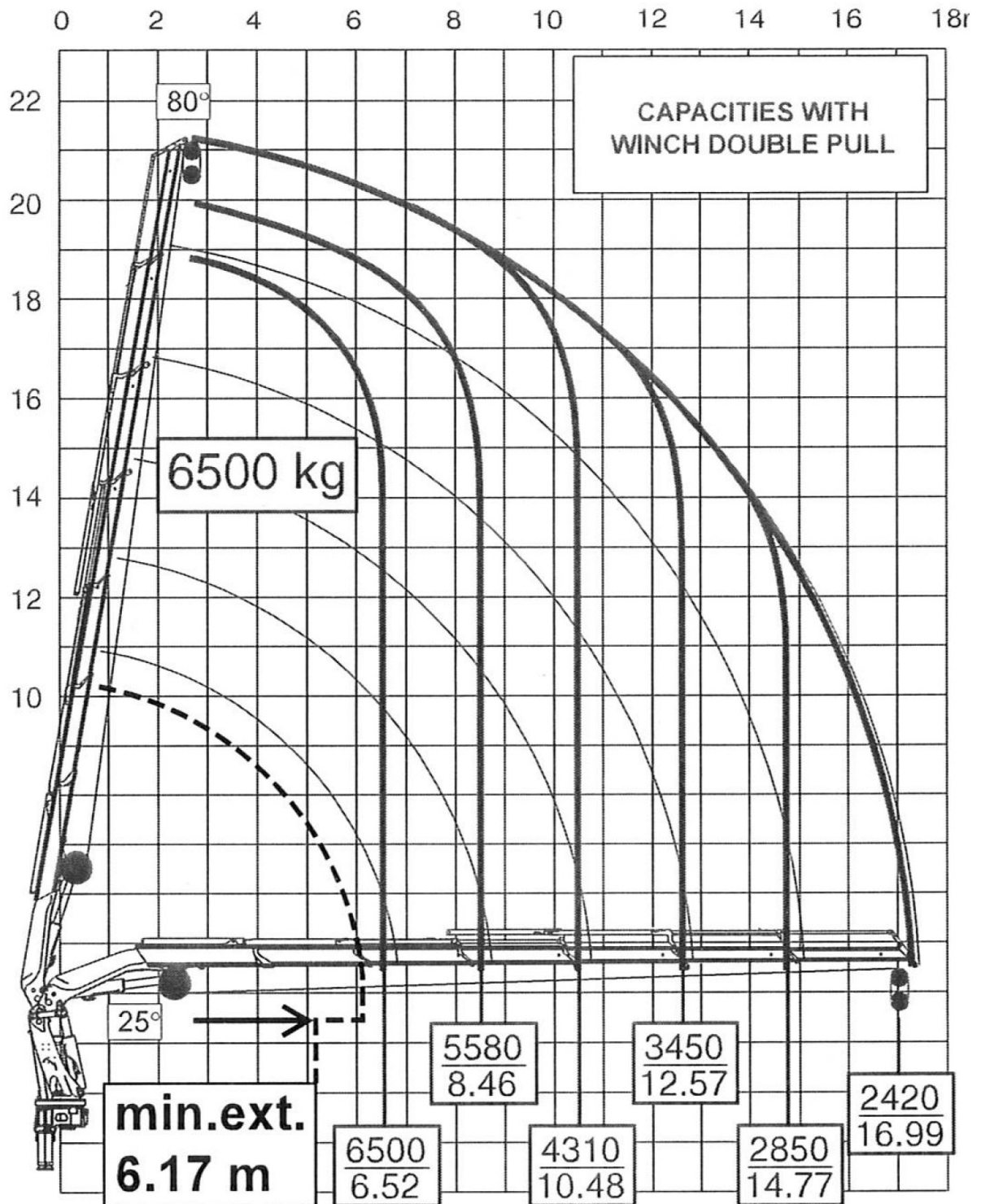

# CAPACITE DE LEVAGE - TRAGLASTEN

DIAGRAMME DE LEVAGE AU TREUIL  
ARBEITSBEREICHE MIT SEILWINDE



**685/6S + JIB 6S heavy duty**  
**PERFORMANCE 100%**

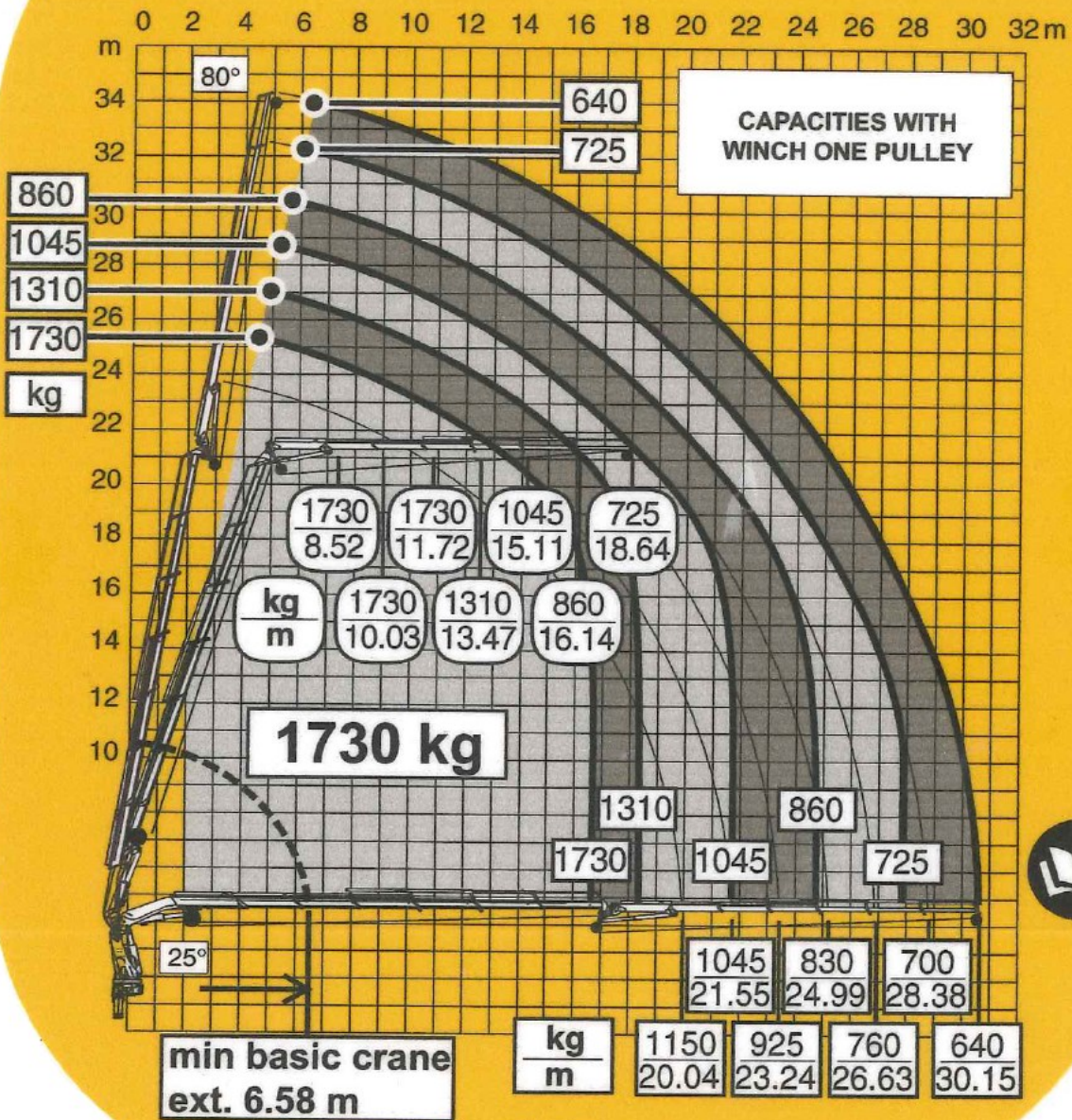

W1900  
cod. AD4R023\_1

EFFER 685 6S