

transport spécial national et international
levage - manutention - entreposage



route du Molliau
CH - 1131 TOLOCHENAZ

tél. +41 (0)21 804 94 94
fax +41 (0)21 804 94 10

www.friderici.com

CAMION 59

MAN TGS 35.500 8X4H-6

EFFER 685 6S + Jib 6S

Camion avec grue 18.8 t / 57.86 tm

LKW mit 18.8 t kran / 57.86 tm

1



Poids à vide*	23.7 tonnes	Charge utile	8.3 tonnes
Dimensions du pont	4.4 x 2.48 mètres	Hauteur du pont	1.11 mètres
Hauteur position route	3.8 mètres	Portée max.	30.09 mètres

*Poids à vide avec Jib: 24.7 to

DIMENSIONS - ABMESSUNGEN

2

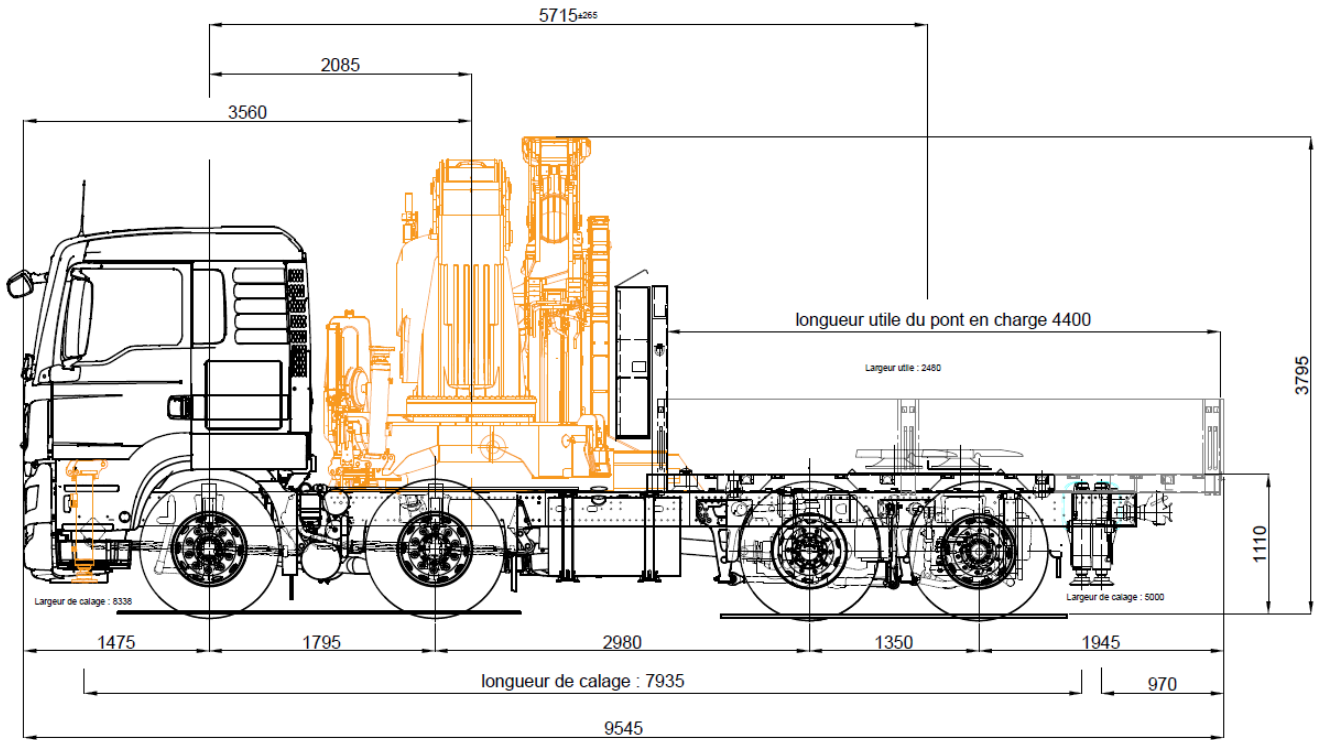

EFFER 685 6S

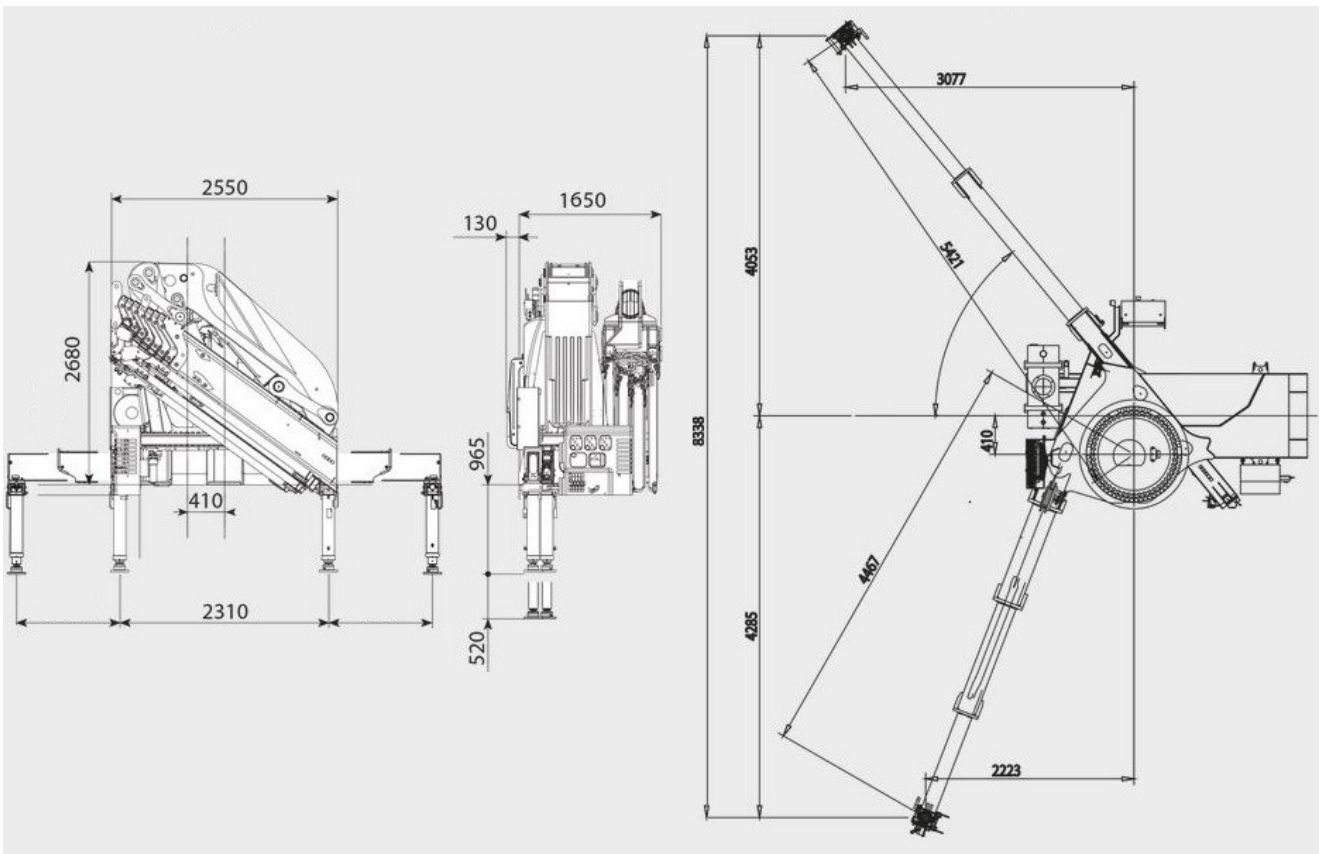

Base de calage : 7.93 x 7.33 - 5m
 Abstützbasis : 7.93 x 7.33 - 5m

CAPACITE DE LEVAGE - TRAGLASTEN

DIAGRAMME DE LEVAGE ARBEITSBEREICHE

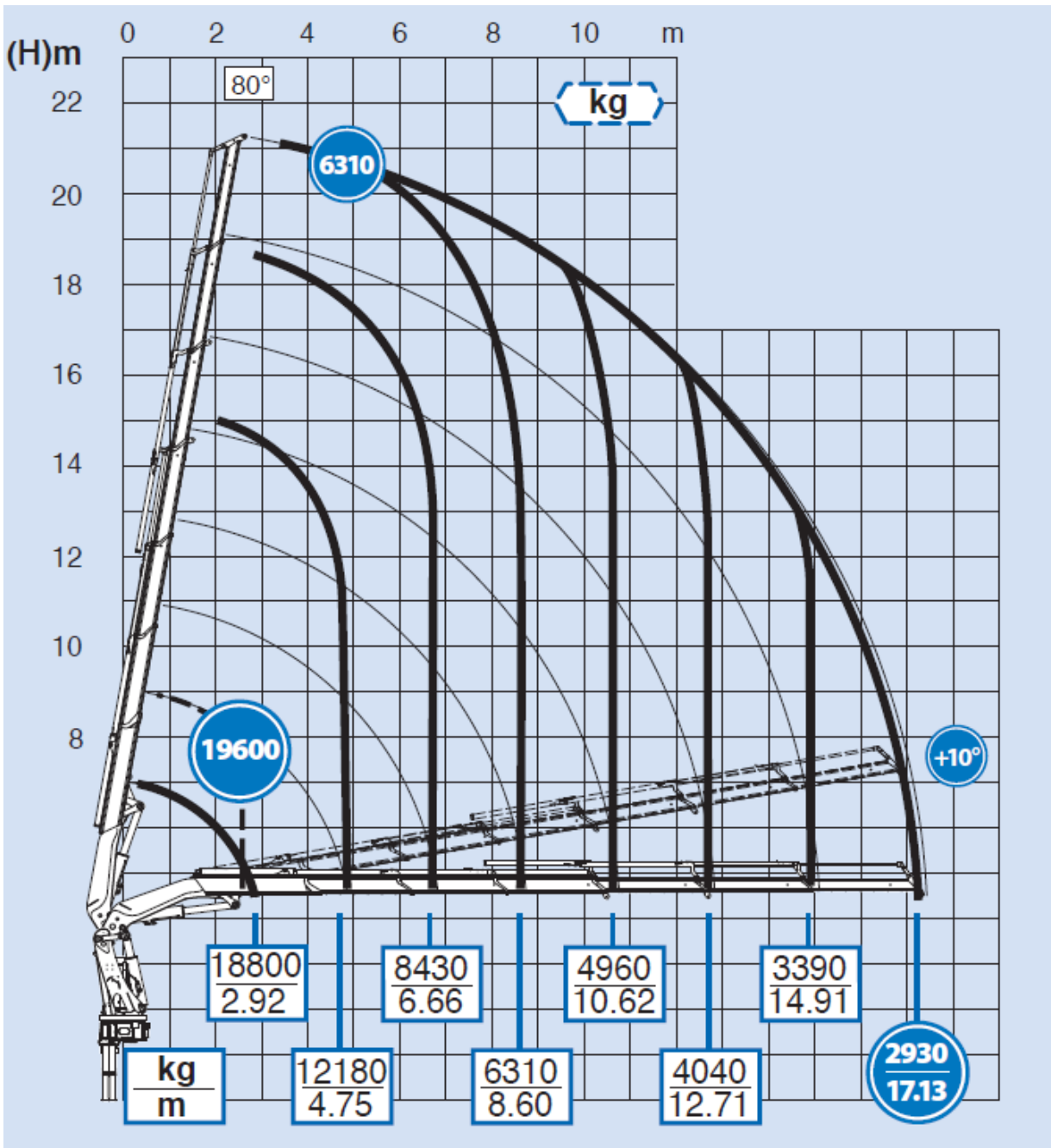

CAPACITE DE LEVAGE - TRAGLASTEN

DIAGRAMME DE LEVAGE AVEC JIB ARBEITSBEREICHE MIT DEM JIB

4

EFFER 685 6S

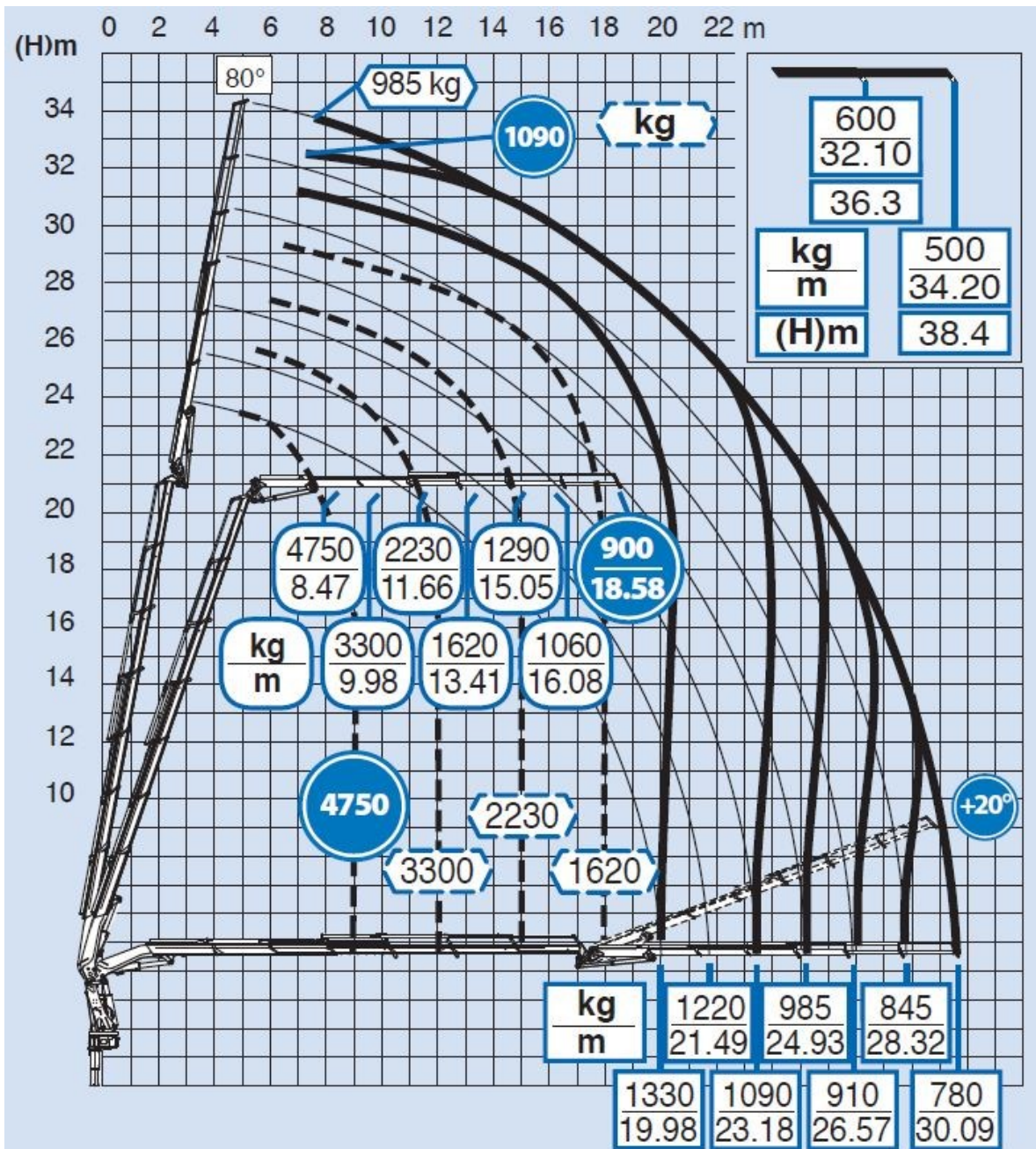

CAPACITE DE LEVAGE - TRAGLASTEN

DIAGRAMME DE LEVAGE AU TREUIL
ARBEITSBEREICHE MIT SEILWINDE



685/6S + JIB 6S heavy duty
PERFORMANCE 100%

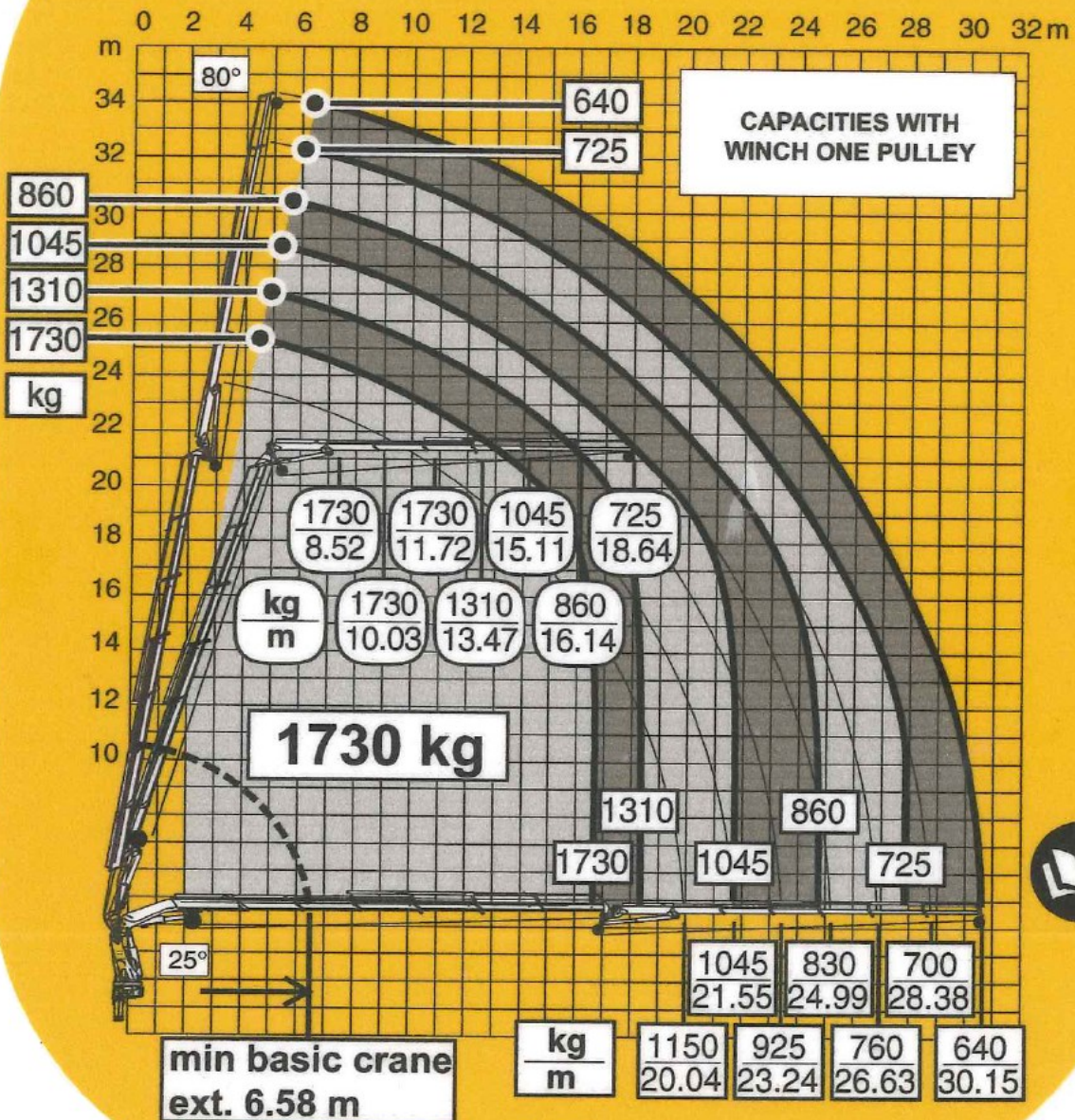

W1900
cod. AD4R023_1

CAPACITE DE LEVAGE - TRAGLASTEN

NACELLE

6



SKY 4 400 ACCIAIO STEEL	1000x2200x1230 mm	360° CONT	205 Kg	400 Kg	1 Kv	4
--------------------------------------	-------------------	--------------	--------	--------	------	---

Richiesto limitatore di carico e kit Fullmatic in conformità con la norma EN 280
Kit Fullmatic & limiting device needed for Norm EN 280

EFFER 685 6S

